

then to the alkoxy group. This observation has been discussed previously in connection with the formation of ion **12** which is preferred over ion **13** by a factor of three.

Experimental Section

Materials. All the trihydroxybenzenes and their methyl ethers were commercially available materials and were used without further purification. Antimony pentafluoride and fluorosulfuric acid were purified as previously described.¹³

Preparation of the Ions. Samples of protonated aromatic compounds were prepared by dissolving approximately 1.5 ml of each of the four superacids in an equal volume of sulfuric chloride fluo-

ride and cooling the solution to -78° . Then to this solution was added with vigorous stirring the trihydroxy(alkoxy)benzenes (approximately 0.2 ml or 0.2 g) at -78° . The resulting clear solution was transferred to an nmr tube for spectral studies.

Nmr Spectra. A Varian Associates Model A56/60A nmr spectrometer equipped with a variable-temperature probe was used to obtain pmr spectra. Proton chemical shifts are referred to external (capillary) TMS. Carbon-13 indor spectra were obtained on a Varian Associate Model HA 100 nmr spectrometer with experimental details described previously.¹⁴

Acknowledgment. Support of our work by the Petroleum Research Fund, administered by the American Chemical Society, and the National Science Foundation is gratefully acknowledged.

(13) G. A. Olah and T. E. Kloovsky, *J. Amer. Chem. Soc.*, **89**, 5692 (1967).

(14) G. A. Olah and A. M. White, *ibid.*, **91**, 5801 (1969).

Nature of the Carbonium Ion. X. The 2-Protoadamantyl Cation¹

Langley A. Spurlock* and Kirtland P. Clark²

Contribution from the Metcalf Research Laboratories, Brown University, Providence, Rhode Island 02912. Received September 13, 1971

Abstract: The syntheses of 2-(endo-bicyclo[3.2.1]oct-6-en-3-yl)ethyl *p*-bromobenzenesulfonate (**5b**) and its saturated analog, **7**, are described. Product studies for the acetolysis, ethanolysis, formolysis, and trifluoroethanolysis of **5b** were conducted. The acetolysis derived products were 2-adamantyl acetate (**14b**), *exo*-2-protoadamantyl acetate (**13c**), *exo*-2-isotwistyl acetate (**25c**), *exo*-10-protoadamantyl acetate (**26c**), *exo*-2-isoprotoadamantyl acetate (**24c**), and unsaturated acetate (**5c**). Only unrearranged acetate was obtained from acetolysis of **7**. Rate measurements of the acetolyses of **5b** and **7** revealed substantial π -orbital participation in ionization of the unsaturated compound. Product compositions suggested a facile hydride shift route, subsequent to ionization, leading to the major 2-adamantyl product. Also described are the syntheses of 2-endo- (**12b**) and 2-exo- (**13b**) protoadamantyl *p*-bromobenzenesulfonates. Solvolysis product studies were conducted in the manner utilized for **5b**. Acetolysis products of **12b** and **13b** were nearly identical in proportion. These products included all the tricyclic acetates detected from **5b** with the addition of 4-twistyl acetate (**23b**). Unlike the **5b** acetolyses, 2-adamantyl acetate was not the major product. A substantial *exo*:*endo* rate ratio (**13b**:**12b** = 10^3) was detected by kinetic measurements of the acetolyses. Formolyses and trifluoroacetolyses of **12b** and **13b** showed considerable variations in product proportions between the epimers. A consolidated interpretation of the cationic pathways for the π -route and σ -route 2-protoadamantyl cations is presented.

Much attention has been given to ten carbon tricyclic derivatives since the discovery by Schleyer and Donaldson of an efficient synthetic route to the adamantyl ring system,³ and the subsequent observations of the biological activities of many compounds with this ring structure.⁴ The majority of the compounds synthesized and studied have been the bridge-head substituted, 1-adamantyl derivatives despite the logic that derivatives with other tricyclic skeleta, isomeric with adamantane (and even bridge-substituted adamantanes), should be of similar interest. This has been primarily due to the nature of the synthetic tech-

niques which take advantage of the extreme stabilities of 1-adamantyl cations and radicals.

We have, by consequence, chosen to investigate alternate routes to these tricyclic derivatives which utilize the carbonium ion rearrangements leading toward adamantanes, but involve solvolytic reactions rather than the stringent Lewis acid conditions of "adamantization." It was felt that the milder conditions of solvolyses would allow isolation of the isomeric skeleta and the 2-adamantyl products. In a previous report,⁵ we described the preliminary results from a solvolytically initiated π -route ring closure which led predominantly to a 2-adamantyl product. We now wish to describe this study in more detail, along with its continuation in which the π -route behavior of the protoadamantyl ion was examined with respect to solvent effects and compared directly with a similar study of the σ -route 2-protoadamantyl ions.

(1) Presented in part at the 157th National Meeting of the American Chemical Society, Minneapolis, Minn., April 1969, Abstracts, ORGN 134.

(2) National Defense Education Act Fellow, 1966-1969.

(3) For a review see: R. C. Fort, Jr., and P. v. R. Schleyer, *Chem. Rev.*, **64**, 277 (1964); V. V. Sevost'yanova, M. M. Krayushlein, and A. G. Yurchenko, *Usp. Khim.*, **39**, 1721 (1970); and P. v. R. Schleyer, *Fortschr. Chem. Forsch.*, **18**, 1 (1971).

(4) See, for example, E. W. Davies, *et al.*, *Science*, **144**, 862 (1964); H. Wendel, *Fed. Proc., Fed. Am. Soc. Exp. Biol.*, **23**, 387 (1964); Grunert, *et al.*, *Virology*, **26**, 262 (1965).

(5) L. A. Spurlock and K. P. Clark, *J. Amer. Chem. Soc.*, **92**, 3829 (1970).

Results

Bicyclo[3.2.1]oct-6-en-3-one (**1**) was prepared through the ring expansion of norbornadiene by the methods of Moore, Moser, and La Prade⁶ and LeBel and Liesemer.⁷ Reduction of **1** with a large excess of sodium in ethanol afforded a mixture of *exo*- and *endo*-bicyclo[3.2.1]oct-6-en-3-ols (see Scheme I).⁸ Analysis of the alcohol mixture by gc showed it to be 95% **2a** and 5% of its *endo* epimer.

Scheme I

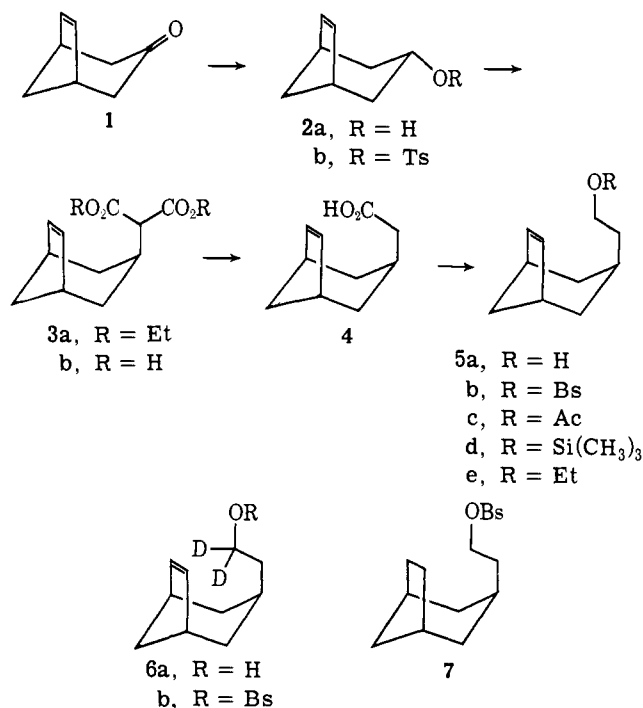

Chromatography on alumina gave pure **2a**, which was converted to the *p*-toluenesulfonate ester **2b** on treatment with *p*-toluenesulfonyl chloride in dry pyridine. The infrared spectrum and melting point of **2b** compared favorably with literature values.⁸ Displacement of the *p*-toluenesulfonate group with potassium diethylmalonate afforded diethyl *endo*-bicyclo[3.2.1]oct-6-en-3-yl malonate (**3a**). Treatment of **3a** with hot aqueous base followed by acidification gave the corresponding diacid **3b**. Decarboxylation of **3b** was complete after 2 hr in pyridine at reflux. Acidification and extraction of the reaction mixture afforded *endo*-bicyclo[3.2.1]oct-6-en-3-yl acetic acid (**4**) in better than 60% overall yield from **2b**. Reduction of **4** was accomplished with lithium aluminum hydride in dry ether to produce 2-(*endo*-bicyclo[3.2.1]oct-6-en-3-yl)ethanol (**5a**). Conversion of **5a** to its *p*-bromobenzenesulfonate ester **5b** was effected by cold treatment of the lithium alkoxide of **5a** with *p*-bromobenzenesulfonyl chloride.

The dideuterio analog of **5b**, 2-(*endo*-bicyclo[3.2.1]oct-6-en-3-yl)ethyl-1,1-*d*₂ *p*-bromobenzenesulfonate (**6b**), was prepared by lithium aluminum deuteride reduction of **4** to the 1,1-dideuterio alcohol (**6a**) followed by conversion to the *p*-bromobenzenesulfonate **6b** as above. The saturated analog of **5b**, 2-(*endo*-bicyclo[3.2.1]oct-3-yl)ethyl *p*-bromobenzenesulfonate (**7**) was prepared from

(6) W. R. Moore, W. R. Moser, and J. E. LaPrade, *J. Org. Chem.*, **28**, 2200 (1963).

(7) N. A. LeBel and R. N. Liesemer, *J. Amer. Chem. Soc.*, **87**, 4501 (1965).

(8) N. A. LeBel and R. J. Maxwell, *ibid.*, **91**, 2307 (1969).

the known⁹ 3-*exo*-bicyclo[3.2.1]octyl *p*-toluenesulfonate by procedures analogous to those used for **5b** and **6b**.

To obtain the desired 2-protoadamantyl derivatives a base-catalyzed cyclization procedure was utilized. *p*-Bromobenzenesulfonate **5b** gave 2-(*endo*-bicyclo[3.2.1]oct-6-en-3-yl)ethyl chloride (**8**) when treated with

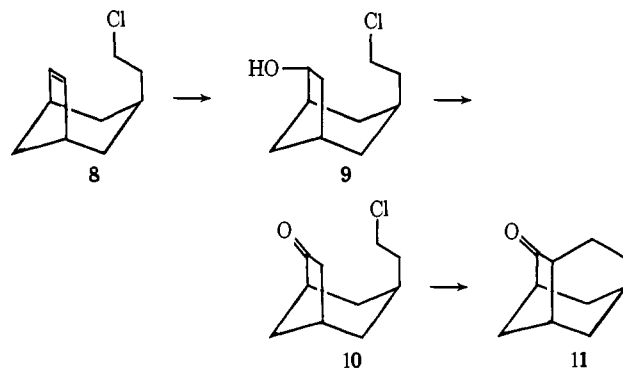

lithium chloride in acetone at 100°. Hydroxylation of the double bond in **8** was accomplished with mercuric acetate and sodium borohydride to afford the corresponding *exo* alcohol (**9**). This was converted with chromic acid¹⁰ to 2-(*endo*-bicyclo[3.2.1]oct-6-en-3-yl)ethyl chloride (**10**). Reaction of **10** with potassium *tert*-butoxide in *tert*-butyl alcohol occurred smoothly to afford 2-protoadamantanone (**11**).

Several methods for reduction of **11** were attempted, and in every case a predominance of *endo*-2-protoadamantol (**12a**) resulted from steric control of the

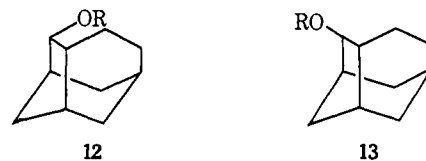

12a, R = H
12b, R = Bs
12c, R = Ac
12d, R = Si(CH₃)₃

13a, R = H
13b, R = Bs
13c, R = Ac
13d, R = Si(CH₃)₃

reducing agent. These studies are summarized in Table I. Conversion of **12a** to **13a** by equilibration

Table I. Reductions of 2-Protoadamantanone (**11**)

Method	% <i>endo</i> 12a ^a	% <i>exo</i> 13a ^a
LiAlH ₄ -Et ₂ O	100	0
NaBH ₄ -MeOH	100	0
NaBH ₄ -pyridine	100	0
Na-EtOH	83	17
Na-MeOH	79	21

^a Determined by gas chromatography of the corresponding trimethylsilyl ethers of **12a** and **13a**.

techniques proved to be exceedingly difficult despite the apparent greater thermodynamic stability of **13a**. For example, from a solution of **12a** in a mixture of fluorenone-aluminum *tert*-butoxide-benzene¹¹ at 150°

(9) W. Kraus, *Chem. Ber.*, **97**, 2719 (1964); C. W. Jefford, D. T. Hill, and J. Gunsher, *J. Amer. Chem. Soc.*, **89**, 6881 (1967); special thanks to Dr. R. J. Schultz for donating a sample.

(10) H. C. Brown and C. P. Carg, *J. Amer. Chem. Soc.*, **83**, 2952 (1961).

(11) A. C. Cope, A. C. Haven, F. L. Ramp, and E. R. Trumbull, *ibid.*, **74**, 4867 (1952).

for 252 hr, a mixture of alcohols was obtained consisting of 76% **12a** and only 24% **13a**. Steric inhibition to hydrogen abstraction was considered to be the reason for the sluggishness of the equilibration. To overcome this effect, a solution of **12a** was heated at reflux in sodium methoxide and methanol (plus a small amount of 2-protoadamantanone) for 325 hr. The mixture of alcohols obtained consisted of 31% **12a** and 69% **13a**. Chromatography of the alcohol mixture on neutral alumina afforded homogeneous samples of **12a** and **13a**. Conversion of these tricyclic alcohols to 2-*endo*-protoadamantyl *p*-bromobenzenesulfonate (**12b**) and 2-*exo*-protoadamantyl *p*-bromobenzenesulfonate (**13b**), respectively, was accomplished by the method previously described for the conversion of **5a** to **5b**.

Solvolytic studies of all the arylsulfonate esters were undertaken. As was anticipated, 2-(*endo*-bicyclo[3.2.1]oct-6-en-3-yl)ethyl *p*-bromobenzenesulfonate (**5b**) gave cyclized products in all solvents utilized. The data in Table II demonstrate the effects of different solvents on the total amount of cyclization.

Table II. Influences of Solvent on the Adamantization of 2-(*endo*-bicyclo[3.2.1]oct-6-en-3-yl)ethyl *p*-Bromobenzenesulfonate (**5b**)

Solvent	<i>T</i> , °C	2-Adamantyl product	Other cyclized products	Uncyclized product
EtOH	100	14	Trace	86
CH ₃ COOH	80	82	12	6
HCOOH	80	81	19	0
CF ₃ CH ₂ OH	100	99	1	0

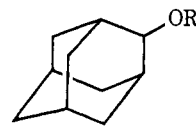

- 14a**, R = H
b, R = Ac
c, R = Ts
d, R = Et
e, R = CH₂CF₃
f, R = Si(CH₃)₃

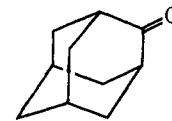

15

ethyl ether was verified by nmr and infrared analyses of the gc isolated solvolysis product. Formolysis products were identified in a manner similar to that subsequently described for acetolysis.

The acetolyses of unsaturated *p*-bromobenzenesulfonate **5b** were carried out under a variety of conditions (summarized in Table III). Identification of the acetate products was made difficult by their poor resolution on gas chromatography. The acetate mixtures were therefore reduced to the corresponding alcohols, and although these were also poorly resolved, the major component of the mixture could be separated from the other alcohols by fractional crystallization. Identity of this major component with 2-adamantanol (**14a**) was established by comparison of the infrared spectrum, nmr, and gas chromatographic retention time with the reduction product of commercially obtained 2-adamantanone (**15**).¹² Conversion of the acetolysis derived alcohols to the corresponding trimethylsilyl ethers afforded much improved separation by gas chromatography. The identities of 2-(*endo*-bicyclo-

Table III. Complete Solvolysis Products of 2-(*endo*-Bicyclo[3.2.1]oct-6-en-3-yl)ethyl *p*-Bromobenzenesulfonate (**5b**)

Solvent	Buffer	<i>T</i> , °C	Relative product ratio					
AcOH	NaOAc Urea	60	6	82	3	7	1	1
			2	85	2	9	Trace	2
			2	85	2	9	Trace	2
AcOH	NaOAc Urea	80	6	81	3	8	1	1
			1	83	3	10	1	2
			1	84	3	9	1	2
AcOH	NaOAc Urea	100	6	78	4	8	2	2
			1	83	3	9	2	2
			1	82	3	9	3	2
EtOH		100	86	14 ^a				
CF ₃ CH ₂ OH		100		99 ^b				
HCOOH		80		81	6	3	3	2 ^c

^a Traces of other tricyclic ethyl ethers were detected. ^b Approximately 1% of other tricyclic trifluoroethyl ethers was observed. ^c The remaining products consisted of 4% of a formate identified as its trimethylsilyl ether **27b** and 1% of a formate giving a trimethylsilyl ether presumed to be **28**.

Identifications of the ethanolysis and trifluoroethanolysis products were conducted in the following manner. Authentic samples of 2-adamantyl ethyl ether (**14d**) and 2-adamantyl trifluoroethyl ether (**14e**) were prepared by solvolyses of 2-adamantyl *p*-toluenesulfonate (**14c**) in the corresponding solvents. The identity of 2-(*endo*-bicyclo[3.2.1]oct-6-en-3-yl)ethyl-

[3.2.1]oct-6-en-3-yl)ethyl trimethylsilyl ether (**5d**) and 2-*exo*-protoadamantyl trimethylsilyl ether (**13d**) were established by comparison of their gas chromatographic retention times with authentic samples prepared from **5a** and **13a**, respectively. Further evidence for

(12) The 2-adamantanone was obtained from the Aldrich Chemical Co., Inc.

5d was its disappearance from gas chromatographs of the trimethylsilyl ethers upon treatment of the acetolysis derived ethers with *m*-chloroperbenzoic acid in chloroform. The remaining three acetolysis products were ultimately identified by procedures to be subsequently described.

Desiring to further elucidate the nature of the rearrangements occurring during the acetolysis of **5b**, 2-(*endo*-bicyclo[3.2.1]oct-6-en-3-yl)ethyl-1,1-*d*₂ *p*-bromobenzenesulfonate (**6b**) was solvolysed under similar conditions to those used for the undeuterated compound. In conjunction with a small α -deuterium kinetic isotope effect (see Table IV), a decrease in the

Table IV. Kinetic Data for Acetolyses with 0.1 M Sodium Acetate Buffer

ROBs	<i>T</i> , °C	<i>k</i> × 10 ⁵ , sec ⁻¹	ΔH^\ddagger , kcal/mol	ΔS^\ddagger , eu
5b	60	0.55 ± 0.03 ^a	24	-12
	80	3.80 ± 0.05		
	100	27.1 ± 0.6 ^{b,c}		
6b	60	0.45 ± 0.01 ^a	30	-1
	100	31.0 ± 0.5 ^b		
7	100	1.52 ± 0.08 ^c	30	-1
	100	1.17 ± 0.17		
12b	130	25.3 ± 0.3	27	+5
	80	0.12 ^d		
	80	127 ± 7		
13b	60	12.2 ± 0.5	27	+5
	80	127 ± 7		

^a $k_H/k_D = 1.22$. ^b $k_H/k_D = 0.87$. ^c $k_U/k_S = 17.8$. ^d Extrapolated from data at higher temperatures.

amount of 2-adamantyl acetate produced was observed. An attempt to determine the amount of deuterium scrambling on the adamantyl skeleton by nmr was, however, unsuccessful.

2-*exo*-Protoadamantyl *p*-bromobenzenesulfonate (**13b**) underwent acetolysis much more readily than did its 2-*endo* isomer (**12b**). The product mixtures, however, were very similar and consisted of six acetates (see Table V). Analyses of the products were much the same as those described for the acetolysis of **5b**, in that the acetolysis mixture was first reduced to the alcohols and a small amount of the alcohol mixture converted to the corresponding trimethylsilyl ethers. As a check on the trimethylsilyl ether analyses, the remaining alcohol mixture was oxidized to ketones. The acetolysis derived ketones were all separable by gas chromatography, and product ratios obtained from their analyses correlated well with those from the trimethylsilyl ethers.

In contrast to the similar acetolysis product mixtures from **12b** and **13b**, their formolysis and trifluoroacetolysis product mixtures differed considerably. Due to the complex product mixtures obtained, the product ratios were again calculated from gas chromatographic analyses of both the corresponding trimethylsilyl ether derivatives and the ketones.

For product identification only three authentic samples of ketones were readily available, 2-protoadamantanone (**11**), 2-adamantanone (**15**), and 4-protoadamantanone (**16**).¹³ The gas chromatographic retention time of **16** showed it to be absent from the

(13) We wish to thank Dr. Lenoir and Professor Schleyer for providing a sample of 4-*exo*- and *endo*-protoadamantanols, which was oxidized with chromic oxide to give **16**.

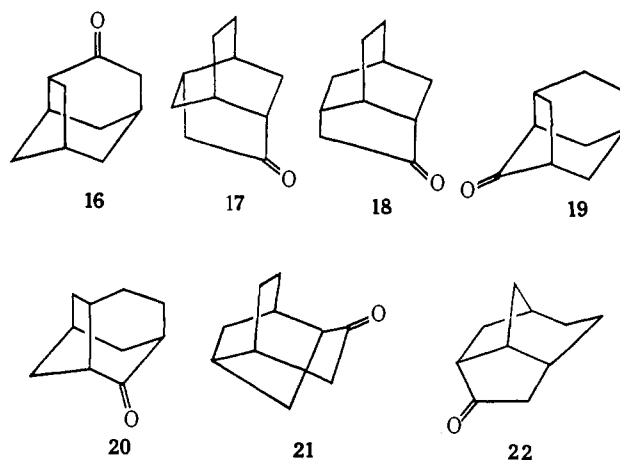

mixture; however, **11** and **15** were observed to be present. Knowledge of the isomeric ketones whose related esters could be plausibly derived from a 2-protoadamantyl cation was considered important. The following are isomers arrived at from considerations of all rational 1,2-carbon and 1,3-hydride shifts: 4-twistanone (**17**), 2-isotwistanone¹⁴ (**18**), 9-protoadamantanone (**19**), 7-protoadamantanone (**20**), 2-isoprotoadamantanone¹⁴ (**21**), and 2-tricyclo[5.2.1.0^{4,9}]decanone (**22**). Identification of the solvolysis derived ketones was initiated by liquid and gas chromatographic separation of each ketone. Next each ketone was passed through a gas chromatographic deuterating column,¹⁵ thereby exchanging all active α protons present for deuterium atoms. A mass spectrum was taken of the ketone before and after passage through the deuterating column. Of the eight ketones in the mixture, four were observed by their parent peak (M^+ *m/e* 150) to exchange no deuterium atoms, three exchanged two deuterium atoms (M^+ *m/e* 152), and one, due to its presence in low yield, could not be unequivocally determined. The ketones with exchangeable protons also showed a mass spectral tendency for loss of ketene (or dideuterioketene) from the parent ion. Since only ketones on a two-carbon bridge fulfill the above criteria for exchange and ketene loss, the latter three ketones must have the structures **17**, **18**, **21**, or **22**. The infrared spectra provided further structural information. The major component of the solvolysis derived ketones possessed a carbonyl absorption at 1740 cm^{-1} , which was characteristic of five-membered ring ketones and valid for **18** and **22**. The other two ketones displayed absorptions at 1720 and 1736 cm^{-1} , respectively. The former was assigned as 4-twistanone (**17**) (lit.¹⁶ infrared C=O stretch, 1718 cm^{-1}). The ketone with absorption at 1736 cm^{-1} was assigned the structure where the carbonyl is incorporated into a strained^{17a} seven-membered ring, 2-iso-

(14) As these ring systems have no previously assigned trivial names we have utilized these designations for simplicity.

(15) We would like to thank Dr. T. E. Parks for a description of the column used. A known possessor of two active α protons, 4-protoadamantanone, was observed by mass spectrometry to be better than 90% *d*₂ and *d*₁ on only one pass through the column.

(16) J. Gauthier and P. Deslongchamps, *Can. J. Chem.*, **45**, 297 (1967); for another synthesis of 4-twistanone see M. Tichy and J. Sicher, *Tetrahedron Lett.*, 4609 (1969).

(17) (a) Indication of the strain in **21** was revealed by Dreiding models of this ketone. (b) The alternate possible structure, 10-protoadamantanone, was ruled out by a comparison of the infrared spectrum of this compound with that of authentic 10-protoadamantanone. (See: C. A. Cupas, W. Schumann, and W. E. Heyd, *J. Amer. Chem. Soc.*, **92**, 3237 (1970)). We are grateful to Professor Cupas for supplying us with the 10-protoadamantanone spectrum.

protoadamantanone (**21**). This assignment was chemically substantiated by reduction of the ketone with lithium aluminum hydride and subsequent conversion of the product to trimethylsilyl ethers. This procedure afforded two isomeric ethers in an approximate ratio of 1 (**24a**) to 10 (**24b**). Upon gc analysis, the larger

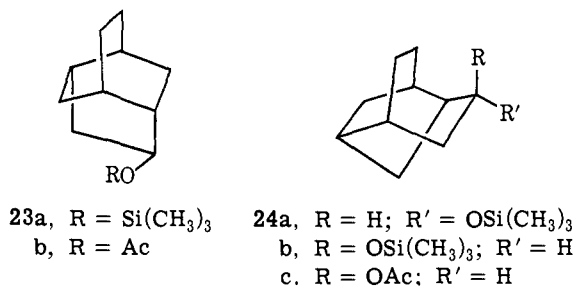

peak was identical in retention time with the solvolysis derived trimethylsilyl ether. This supported the ketone assignment of **21**, since molecular models suggested that hydride delivery to the carbonyl would occur mainly from the face opposite that expected for solvent attack on the corresponding carbonium ion.

As noted above, the major acetolysis component from the physical evidence available could be assigned either structure **18** or **22**. Since a solvolysis product leading to **18** can be obtained from the 2-protoadamantyl cation by only one 1,2-carbon shift, while the formation of **22** requires a 1,3-hydride shift (normally considered to be slower than 1,2-carbon shifts) followed by a 1,2-carbon shift, the major acetolysis derived ketone was assigned as 2-isotwistanone (**18**). Ketone **22** was then assigned as the low yield ketone present only in the formolysis and trifluoroacetolysis derived ketone mixture.

The identification of the ketones not possessing active α positions was simplified by converting the solvolysis derived ketone mixture (from trifluoroacetolysis) to the corresponding hydrocarbons by a Wolff-Kishner reduction. By this technique, three ketones were observed to possess the protoadamantane skeleton. The two remaining unidentified ketones were therefore confirmed as protoadamantanones possessing structures **19** and **20**. Again, these structures could be easily differentiated by their infrared carbonyl stretching frequencies. The identity of 9-protoadamantanone (**19**) was confirmed by its absorption maxima at 1740 and 1748 cm⁻¹ (due to the incorporation of the carbonyl into a strained five-membered ring). The remaining compound was assigned as 7-protoadamantyl (**20**) since this was the only remaining protoadamantyl ketone fitting the existing information.^{17b}

Having identified all of the solvolysis derived ketones, a correlation of the ketones with the acetolysis-obtained trimethylsilyl ethers was considered important in determining the number of stereoisomers present before oxidation. Upon examination of the trimethylsilyl ethers derived from the acetolysis of **5b**, **12b**, and **13b**, an exact correlation was observed between the trimethylsilyl ethers and ketones. This indicated the absence of any stereoisomeric pairs. The acetate stereoisomer, in each case, was proven to be the exo isomer by one of the two methods. The identity of 2-*exo*-protoadamantyl trimethylsilyl ether (**13d**) was established by comparison of its gc retention time with that of an

Table V. Solvolysis Products of *exo*- (**13b**) and *endo*- (**12b**) 2-Protoadamantyl *p*-Bromobenzenesulfonates

ROBs	Solvent	T, °C	Relative product ratio										
	AcOH	60	6	16	60	3	6	6	9	9	12	6	1
		80	5	10	64	3	6	6	12	12	19	6	28 ^b
	HCOOH CF ₃ COOH	80	13	26	26	4	19	7	5	5	9	9	4
		80	11	18	9	14 ^b	7	7	9	9	9	9	4
	AcOH	100	20	11	53	4	6	6	11	11	13	2	
		130	18	13	50	5	6	6	13	13	19	2 ^b	
	HCOOH CF ₃ COOH	100	34	10	10	16	9	9	Trace	Trace	Trace	Trace	1
		80	30	59 ^a	3	3 ^b	2	2	2	2	2	2	1

^a The 2-protoadamantyl trifluoroacetate was shown to be solely the *endo* epimer. ^b Mixtures of epimers were detected in these cases. In all other cases only a single epimer was found.

authentic sample. Determination of the other isomers was necessarily accomplished deductively. Examination of molecular models of ketones **18**, **19**, **20**, and **21** suggested that sterically-controlled lithium aluminum hydride reactions of **18**, **19**, and **20** would give the endo alcohols while **21** would yield predominantly the exo alcohol. Upon reduction of each ketone and subsequent trimethylsilylation of the product alcohols, the resultant trimethylsilyl ethers **25a**, **27a**, and **26a** from **18**, **19**, and **20**, respectively, possessed gc retention times different from the solvolysis derived trimethylsilyl ethers. The major product from reduction of **21**, as previously noted, was identical with the solvolysis derived **24b**. The trimethylsilyl ether (**28**), obtained in low solvolytic yield, was assumed to be the exo isomer due to an anticipated inhibition to endo solvent approach. Unlike acetolysis, formolysis and trifluoroacetolysis of **13b** afforded, in two cases, two pairs of stereoisomers, **26a**, **26b** and **27a**, **27b**. Trifluoro-

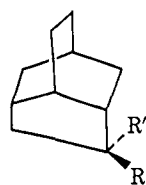

25a, R = H; R' = OSi(CH₃)₃
b, R = OSi(CH₃)₃; R' = H
c, R = OAc; R' = H

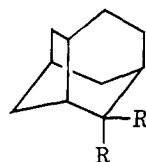

26a, R = H; R' = OSi(CH₃)₃
b, R = OSi(CH₃)₃; R' = H
c, R = OAc; R' = H

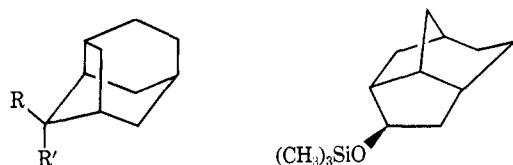

27a, R = H; R' = OSi(CH₃)₃
b, R = OSi(CH₃)₃; R' = H

acetolysis of **12b** likewise provided an alternate stereoisomer. In this case the product of retained structure and configuration was the only 2-protoadamantyl trifluoroacetate detected.

Rate measurements of the acetolysis of 2-(endo-bicyclo[3.2.1]oct-6-en-3-yl)ethyl *p*-bromobenzenesulfonate (**5b**) in glacial acetic acid demonstrated linear first-order kinetics (summarized in Table IV) at all temperatures employed and under every buffering condition. Sodium acetate buffered acetolyses of its saturated and deuterated analogs (**7** and **6b**, respectively) similarly showed excellent first-order kinetics, and, in addition, a small α -deuterium isotope effect at 60° for the latter. The rate measurements of the acetolyses of the tricyclic isomers **12b** and **13b** were also conducted only in a buffered medium and gave linear first-order kinetics at both temperatures utilized for each isomer.

Discussion

Though 2-(endo-bicyclo[3.2.1]oct-6-en-3-yl)ethyl *p*-bromobenzenesulfonate (**5b**) readily underwent the desired π -route ring closures, upon solvolyses in a variety of solvents, the efficient capture of the initial π -route cation by the solvent before rearrangement proved surprisingly difficult. The prominence of 2-adamantyl products in every solvent would seem to imply that a facile pathway exists for the rearrangement of the initial π -route cation to the adamantyl cation. This is understandable if one considers the initially formed ion(s) from π -orbital participation in ionization of **5b** to be **29** (or **30** and **31**). Conversion of the delocalized cation **29** (or the equilibrating pair

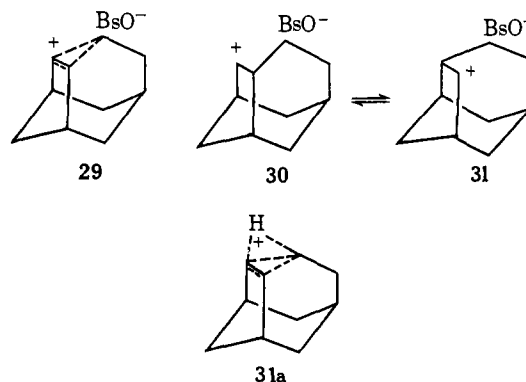

of localized ions, **30** and **31**) to the adamantyl framework requires only a 1,3-hydride shift followed by a 1,2-carbon shift. Processes such as these have been observed to occur rapidly for π -route carbonium ions of the norbornyl system.¹⁸ The prime driving force for such a rearrangement in this system could, indeed, be the attainment of the exceptionally stable adamantane skeleton. One may further conclude that whatever the reason, the initial hydride shift must be extremely rapid for 2-adamantyl products to predominate. Such a hydride shift could conceivably occur during the ionization process giving rise to the protonated cyclopropane **31a**. A significant contribution by **31a** during the rate-determining step should be detected through isotopic labeling studies. The fact that acetolysis of the deuterated *p*-bromobenzenesulfonate **6b** proceeded at a rate only slightly less than that of **5b** at 60° infers that significant bridging does not occur during the rate-determining step. The contribution of the protonated cyclopropane **31a** to ionization was thereby ruled out. One can further conclude from the labeling study that the initially obtained ion from **5b** is *not* adamantyl in structure despite the likelihood of additional stabilization from its formation.

The observed isotope effects provided further support for a transition state with a cation resembling **29**. The normal α -deuterium kinetic isotope effect expected for S_N1 reactions occurring at a carbon bearing two deuterium atoms is $k_H/k_D = 1.30$.^{19,20} It has been predicted that participation by π orbitals in the rate-determining step should cause a decrease in the isotope effect.²⁰ By this logic, as the participa-

(18) For example, see C. J. Collins and M. H. Lietzke, *J. Amer. Chem. Soc.*, **89**, 6565 (1967); B. M. Benjamin and C. J. Collins, *ibid.*, **92**, 3182, 3183 (1970).

(19) C. C. Lee and E. W. C. Wong, *Tetrahedron*, **21**, 539 (1965).

(20) A. Streitwieser, Jr., R. H. Jagrow, R. C. Fahey, and S. Suzuki, *J. Amer. Chem. Soc.*, **80**, 2326 (1958).

tion increases, k_H/k_D should approach unity (as in the case of a pure S_N2 reaction) and possibly even become inverse. Lee and Wong¹⁹ found these predictions to be essentially correct for the acetolysis of 2-(Δ^3 -cyclopentenyl)ethyl *p*-nitrobenzenesulfonate which demonstrated a $k_H/k_D = 1.14$ at 60–65°. From their results, they predicted that the α -deuterium isotope effect should be, to some extent, temperature dependent. This prediction was realized during the acetolyses of **6b** when the small α -deuterium isotope effect at 60° ($k_H/k_D = 1.22$) became inverse at 100° ($k_H/k_D = 0.87$). For an effect such as this to occur, π -orbital participation (anchimeric assistance) to ionization must be a favorable pathway. A quantitative measure of this assistance was determined from the rate ratio of the unsaturated arylsulfonate **5b** and the saturated analog **7** ($k_u/k_s = 17.8$). Schleyer²¹ has recently shown that the amount of direct solvent displacement products can be predicted from the relative magnitudes of the solvent-assisted rate (assumed to be equal to the acetolysis rate of **7**) and the π -assisted rate. Using this approach the amount of unsaturated acetate **5c** received was estimated to be 5.6% while in fact it was found to comprise 6.0% of the mixture.

The acetolysis of **5b** demonstrates the largest degree of π -orbital influence on ionization and product formation observed for any arylsulfonate with a double bond separated by a *minimum* of four carbon atoms from the site of dissociation. Of the acetolyses conducted^{22–24} to date on arylsulfonate systems of this type, *only* 3-(3,4-dimethyl- Δ^3 -cyclopentyl)propyl *p*-nitrobenzenesulfonate has shown any significant double bond involvement in the rate ($k_u/k_s = 4.0$) and products (58% cyclization) of acetolysis. The more facile nature of the π -route solvolysis of **5b**, even without the stabilizing effect of the two methyl substituents, is clearly indicated. The reason for the effectiveness of π participation in **5b** may be gathered from molecular models which reveal that no conformational barrier exists for an approach of the reaction site to the double bond. Furthermore, the relatively rigid conformation of the bicyclic system which forces the site of dissociation to spend more time in the region of the double bond would be expected to favor more π participation. It is in fact striking that double bond participation was observed even under the extremely nucleophilic conditions of ethanolysis, where 14% of 2-adamantyl ethyl ether (**14d**) was formed.

Differentiation between **29** and **30** \rightleftharpoons **31** as the first-formed intermediates during solvolysis would be informative; however, current experimental techniques do not allow for this. Recent analyses by Collins and Lietzke¹⁸ of tracer experiments²⁵ have inferred that the π -route cations derived from 2-(Δ^3 -cyclopentenyl)ethyl *p*-nitrobenzenesulfonate are more easily explained as classical. By analogy, this would indicate that the equilibrating ions, **30** \rightleftharpoons **31**, would be pre-

ferred over the bridged species **29**. Whether or not this is true, the solvolysis products will be determined by the rate at which the protoadamantyl ion(s) rearranges compared with the rate of solvent capture.

Thus far only the nature of the initial π -route carbonium ion has been considered. Of equal importance are the subsequent rearranged ions leading to most of the observed products. All acetolysis products described in Table III are derivable by a maximum of two migrations from the initial ion (which for the sake of simplicity will be defined as **31**). The 1,3-hydride migration to give the 4-protoadamantyl cation (**32**) which rapidly undergoes a 1,2-carbon shift to afford the 2-adamantyl cation (**33**) has already been mentioned. The absence of 4-protoadamantyl products from attack on cation **32** is not totally unexpected if one considers that Lenoir and Schleyer²⁶ were also unable to trap such products from hydrolysis of 4-*exo*-protoadamantyl 2,4-dinitrobenzoate. In explanation of the remaining products, rearrangement of **31** to afford the isotwistyl cation **34** requires only a simple Wagner–Meerwein shift. Similarly **31** must undergo a 1,3-hydride shift to give cation **35** which affords the 7-protoadamantyl products following a subsequent 1,3-hydride shift. Finally, cation **35** must effect an additional 1,2-carbon shift to give cation **36** which

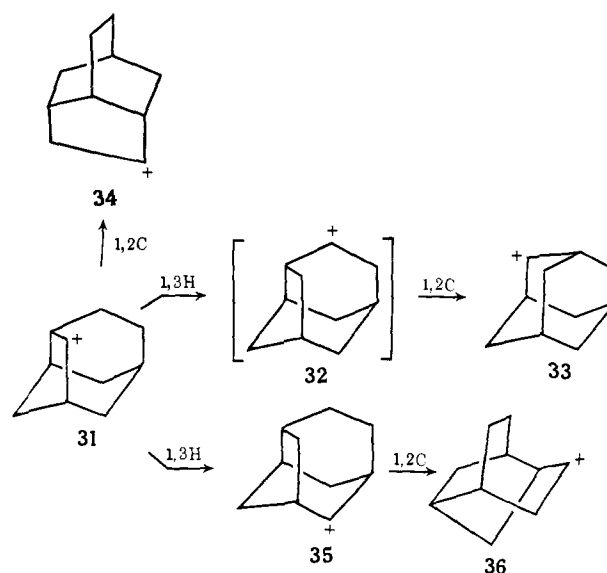

results in the 2-isoprotoadamantyl products.

It is apparent from the above results that rearrangements are easily accomplished in the protoadamantyl system generated by the π route. Further definition of these rearrangements is possible from the considerations of the σ -route 2-protoadamantyl cations in the subsequent discussion. The easy synthesis of 2-protoadamantanone (**11**), accomplished through normal intramolecular cyclization, reveals the lack of excessive strain in the molecule. Reductions of **11** demonstrated that the two faces of the carbonyl are drastically different with the endo face being much more hindered than the exo. The origin of the observed steric hindrance was ascertained from molecular models to be the C₅ endo proton. On the basis of these observations it seems justified to assume that endo approach to the 2-protoadamantyl cation by a nucleophile would be similarly inhibited.

(21) For a discussion of this technique, see J. M. Harris, F. L. Schadt, P. v. R. Schleyer, and C. J. Lancelot, *J. Amer. Chem. Soc.*, **91**, 7508 (1969). We are grateful to Professor Schleyer for his suggestions concerning this treatment of our data.

(22) P. D. Bartlett, W. S. Trahanovsky, D. A. Bolon, and G. H. Schmid, *ibid.*, **87**, 1314 (1965).

(23) W. S. Johnson, D. M. Baily, R. Owyang, R. A. Bell, B. Jacques, and J. K. Crandall, *ibid.*, **86**, 1959 (1964).

(24) W. S. Trahanovsky and M. P. Doyle, *Tetrahedron Lett.*, 2155 (1968).

(25) C. C. Lee and K. M. Lam, *J. Amer. Chem. Soc.*, **88**, 3834 (1966).

(26) D. Lenoir and P. v. R. Schleyer, *Chem. Commun.*, 941 (1970).

The results in Table IV reveal that the initial ionization processes for **13b** and **12b** must be vastly different since the *exo:endo* rate ratio is 1.04×10^3 . Two factors known to influence this ratio are anchimeric assistance and steric hindrance.²⁶ Even in the absence of anchimeric assistance, **12b** would be expected to ionize less efficiently than **13b** due to the steric hindrance to expulsion of the leaving group from the *endo* position. Furthermore, examination of a molecular model of **13b** indicates that the C₁-C₁₀ bond is antiperiplanar to the leaving group, thereby allowing anchimeric assistance to ionization from the *exo* site. No similar arrangement prevails for the *endo*-substituted **12b**. Both anchimeric assistance and steric hindrance, therefore, can be invoked to explain the large *exo-endo* rate ratio. The σ -route ion pairs **37** (or **38** and **39**) and **40** are anticipated to be the initial species derived from **13b** and **12b**, respectively. The cationic portion of **38** (and **40**) is reminiscent of the π -route cation **31**; how-

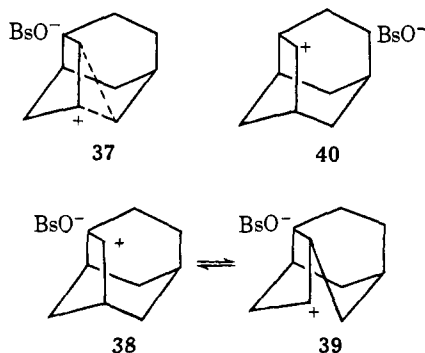

ever, recent studies by Collins²⁶ indicate that the position of the counter ion is important in solvent capture. This could in part be the reason for the small amounts of 2-*exo*-protoadamantyl acetate (**13c**) obtained from **13b** as compared with the large amount of 2-*exo*-isotwistyl acetate (**25c**), since the leaving group probably blocks initial solvent approach to the *exo* face at C₂. Reinforcement for this concept is found in the increased proportion of **13c** with respect to **25c**, found on acetolysis of **12b**. One need only regard the position of the anion in **40** to understand this occurrence. The common intermediate through which both 2-protoadamantyl *p*-bromobenzene-sulfonates pass probably contains a cationic portion resembling that in **37** since cation **40** should obtain better stabilization through charge delocalization.

Additional information on subsequent cations is derivable from solvolyses in the better ionizing solvents formic and trifluoroacetic acid. The most striking characteristic of the results in Table V is the difference between the *endo*- and the *exo*-derived products from formolysis and trifluoroacetolysis. This dissimilarity of product proportions is probably due to solvent stabilization of **40** and the resultant lessening of its tendency to give the common intermediate assumed for acetolysis. Scheme II summarizes the likely solvolytic pathways for **5b**, **13b**, and **12b** in acetic acid and formic acid. The products placed below the 2-protoadamantyl cation (**40/31**) are derived from multiple rearrangements and are unimportant in acetolysis. In formolysis, further rearrangements occur with greater efficiency due to the increased lifetime of the cations and the resultant greater ease of 1,3-hydride shifts.

An increase in secondary products when less nucleophilic solvents are used is thus easily reconciled, and is borne out well, since acetolysis of **13b** gave 18% of the complex 1,3-hydride shift products, formolysis afforded 31%, and trifluoroacetolysis, 62%. A similar effect was observed for **12b** and **5b**. The appearance of epimeric *endo* products during trifluoroacetolysis is likewise attributable to increased cation lifetime and solvent stabilization. The σ -route cations obtained on ionizations in trifluoroacetic acid behave quite differently from those generated in acetolysis and formolysis. This is comprehensible if one recognizes that trifluoroacetic acid, due to its potent ionizing ability, but weak nucleophilicity,^{27,28} is an excellent medium for observing near "limiting" S_N1 behavior in solvolytic reactions. One may predict that solvation of the anion should free the ionization site for attack by the solvent. This does apparently occur with **12b** and **13b**, affording larger proportions of the retained configuration products, 2-*exo*- and *endo*-protoadamantyl trifluoroacetates, respectively.

Solvolyses of **5b**, **12b**, and **13b** have demonstrated several broad principles. Mainly, rearrangements occur freely from a 2-protoadamantyl cation to give, depending on the nucleophilicity of the solvent, a wide spectrum of tricyclic products. For such an occurrence, all tricyclic skeleta obtained can be considered to be energetically similar²⁹ except for the adamantyl skeleton. Support for this theory was found in the slow isomerization of all acetolysis-derived alcohols to 2-adamantanol when stored for several months at room temperature. Also with this was the observed secondary conversion of the trifluoroacetolysis products from **12b** and **13b** to 100% 2-adamantyl trifluoroacetate by heating at 100° for 3 hr. The original notion of Schleyer³ that interconversions of the tricyclic systems continue until they find their way into the adamantyl energy well would appear to be quite correct even in these less stringent solvents. Secondly, product mixtures can be dictated, at least in part, by the initial location of the counter ion. Finally, it should be noted that the initial premise that entrance into the adamantane system can be efficiently accomplished through a π -route ring closure of a nonadamantyl derived precursor has been proven correct.

Experimental Section³⁰

Bicyclo[3.2.1]oct-6-en-3-one (1) was prepared from norbornadiene and bromoform by the method of LeBel and Liesemer⁷ in an overall yield of 11%: infrared spectrum (CCl₄) 3010, 2910, 1703, 1343, 982, and 865 cm⁻¹ (lit.⁷ 3020, 2930, 1700, 1342, 975, and 860 cm⁻¹).

exo-**Bicyclo[3.2.1]oct-6-en-3-ol (2a)**. To 4.22 g (34.6 mmol) of **1** dissolved in 400 ml of absolute ethanol being stirred at room temperature under nitrogen atmosphere was added 21.4 g (0.93 g-atom) of sodium metal in small pieces over a 2-hr period. After complete solution of the sodium, the mixture was heated at reflux for 45 min, allowed to cool, and poured into 700 ml of ice water. Extraction of the resulting mixture with pentane for 72 hr afforded

(27) J. E. Nordlander and W. J. Kelly, *J. Amer. Chem. Soc.*, **91**, 996 (1969).

(28) J. E. Nordlander and W. G. Deadman, *ibid.*, **90**, 1590 (1968).

(29) This had been previously predicted. See: H. W. Whitlock, Jr., and M. W. Siefken, *ibid.*, **90**, 4929 (1968).

(30) Infrared spectra were determined with a Perkin-Elmer 237 or Infracord using sodium chloride optics. The nmr determinations were carried out on a Varian Associates A-60A spectrometer; approximately 20% solutions in carbon tetrachloride were employed with tetramethylsilane as the internal standard. Analyses were carried out by Micro-Analysis Inc. of Wilmington, Del.

Scheme II

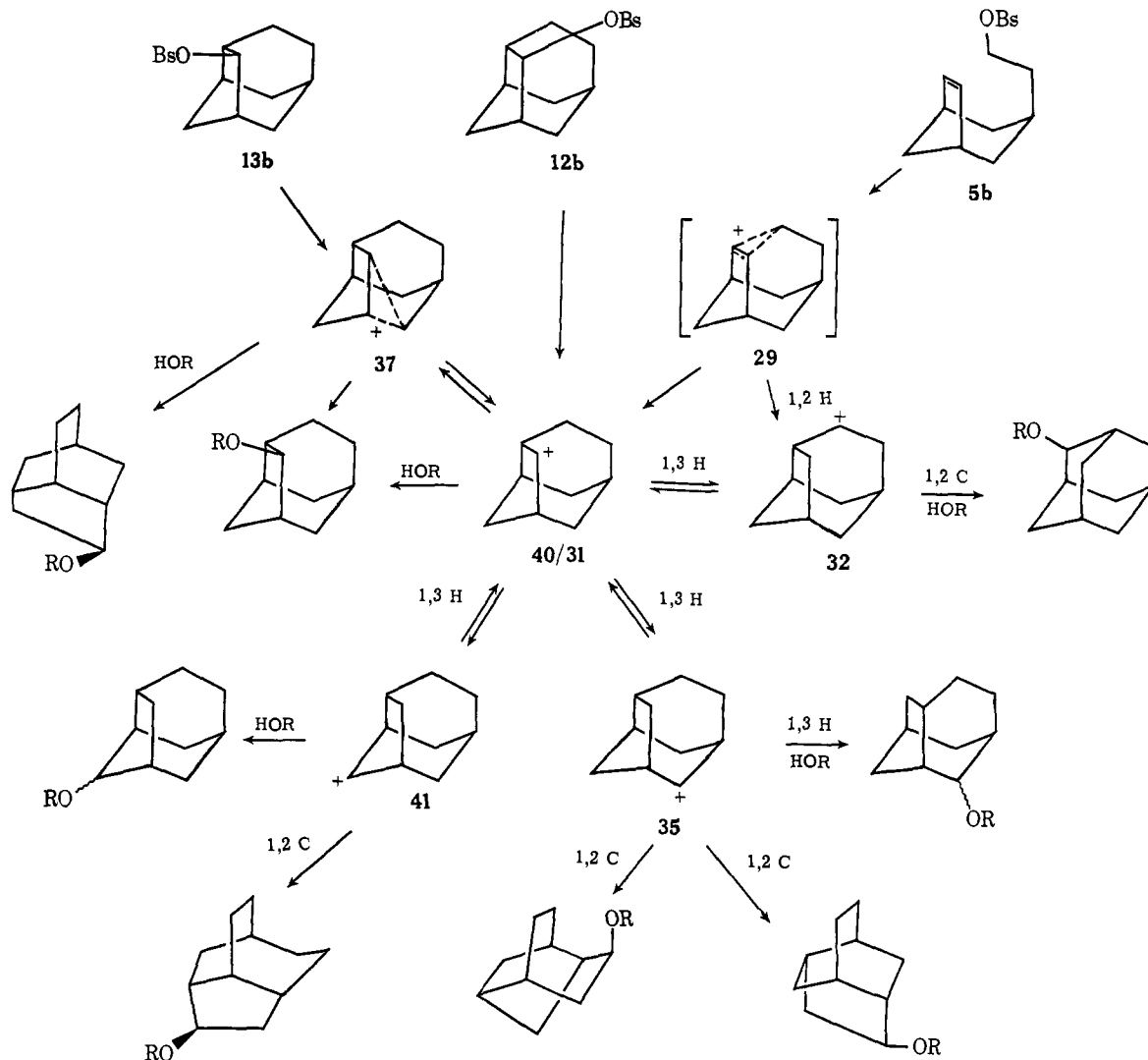

3.892 g (90.9%) of crude alcohol upon removal of the solvent. Crystallization from ether-pentane solution gave 3.19 g (82%) of **2a**, mp 112–114°. A gas chromatogram on a 12-ft Carbowax column showed that there was 95% of **2a** and 5% of the endo isomer present: **2a** infrared spectrum (CS₂) 3300, 3010, 2900, 1105, 1080, 1050, and 968 cm⁻¹; nmr (CDCl₃) τ 4.27 (s, 2 H), 6.3 (mult, 1 H), 7.39 (broad s, 2 H), 7.87–9.05 (mult, 7 H).

exo-Bicyclo[3.2.1]oct-6-en-3-yl p-Toluenesulfonate (2b). To 4.65 g (37.4 mmol) of **2a** in 25 ml of pyridine being stirred at 0° was added dropwise 8.56 g (44.9 mmol) of *p*-toluenesulfonyl chloride in 15 ml of pyridine. The temperature of the mixture was kept below 5° during the addition. After complete addition, the mixture was allowed to stand at 0° overnight. The mixture was poured into 75 ml of ice water and extracted four times with 50-ml portions of 50% ether-pentane. The combined extracts were washed three times with 50-ml portions of cold 10% hydrochloric acid and once with 50 ml of saturated sodium bicarbonate solution, dried, and concentrated affording 10.0 g of crude **2b**. Crystallization from ether-pentane gave 9.6 g (92%) of white crystals: mp 60–62°; infrared spectrum (Nujol) 3010, 2920, 1600, 1190, 1180, 950, and 872 cm⁻¹.

endo-Bicyclo[3.2.1]oct-6-en-3-ylacetic Acid (4). To 200 ml of *tert*-butyl alcohol, freshly distilled from sodium, was added 1.70 g (43.6 mg-atoms) of potassium metal and the mixture was stirred at reflux under a nitrogen atmosphere until all potassium had dissolved. To this solution was added 7.05 g (44 mmol) of freshly distilled diethylmalonate. The mixture was allowed to stir for another 0.5 hr and 10.00 g (36 mmol) of **2b** dissolved in 50 ml of *tert*-butyl alcohol was added in one portion. The mixture was brought to reflux and the excess *tert*-butyl alcohol distilled until a heavy slurry remained. After 17 hr at reflux the slurry was cooled, poured into 400 ml of ice water, and acidified to pH 3. This

mixture was extracted with four 50-ml portions of 50% ether-pentane and the combined extracts were washed with three 50-ml portions of water. The water layers were combined, saturated with sodium chloride, and extracted twice with 50-ml portions of 50% ether-pentane. These extracts were combined with the previous ones, dried, and concentrated affording 10.65 g of crude diethyl *endo*-bicyclo[3.2.1]oct-6-en-3-yl malonate (**3a**). The diester was not purified but added directly to a hot solution of 38 g of potassium hydroxide in 40 ml of water. This mixture was shaken and heated on a steam bath for 90 min. After cooling, the solution was extracted with two 25-ml portions of ether to separate out all unreacted *p*-toluenesulfonate and then acidified with iced 6 *N* hydrochloric acid to pH 2. Extraction of the acidified mixture with four 50-ml portions of ether and one 50-ml portion of pentane, after drying and concentration, gave 5.08 g of crystalline *endo*-bicyclo[3.2.1]oct-6-en-3-ylmalonic acid (**3b**).

The diacid was heated at reflux in 35 ml of pyridine until no more carbon dioxide was evolved (approximately 2 hr). The cooled mixture was then poured into ice water, acidified to pH 2, and extracted four times with 25-ml portions of ether. The combined extracts were dried and concentrated to obtain 3.77 g (63%) of **4**. An analytical sample was obtained by ether-pentane recrystallization of a small portion of the crude material: mp 58.5–60°; infrared spectrum (CCl₄) broad band 3500–2400, 2950, 1620, 1305, 950, and 723 cm⁻¹; nmr (CDCl₃) τ 1.00 (s), 4.04 (s), 7.50 (d), 7.70–9.30 (mult).

Anal. Calcd for C₁₀H₁₄O₂: C, 72.24; H, 8.49; Found: C, 72.04; H, 8.53.

2-(endo-Bicyclo[3.2.1]oct-6-en-3-yl)ethanol (5a). To 0.233 g (6.2 mmol) of lithium aluminum hydride being stirred at reflux in 20 ml of ether was added dropwise 1.02 g (6.2 mmol) of **4** dissolved in 5 ml of ether. The mixture was stirred at reflux for 18 hr and cooled, and 0.25 ml of water added followed by 1 ml of 15%

potassium hydroxide solution. The precipitated salts were removed by filtration and the filtrate was dried and concentrated to obtain 1.98 g of crude material. This residue was distilled at 70–75° (0.08 mm) to give 775 mg (82.9%) of pure alcohol **5a**. Preparative gc afforded an analytical sample: infrared spectrum (film) 3300, 3010, 2910, 1358, 1060, 1042, and 718 cm⁻¹; nmr (CDCl₃) τ 4.17 (s), 6.55 (tr), 7.12 (s), 7.52 (s), 7.90–9.00 (mult).

Anal. Calcd for C₁₀H₁₆O: C, 78.88; H, 10.60. Found: C, 78.77; H, 10.44.

2-(endo-Bicyclo[3.2.1]oct-6-en-3-yl)ethyl p-Bromobenzenesulfonate (5b). To a solution of 579 mg (3.8 mmol) of **5a** in 5 ml of tetrahydrofuran being stirred at 0° was added 2.5 ml of a 15% *n*-butyllithium solution in hexane. After being stirred for 1 hr, 1.170 g (4.6 mmol) of *p*-bromobenzenesulfonyl chloride in 10 ml of dry tetrahydrofuran was added dropwise. The resulting mixture was stirred for 3 hr and stored at 0° overnight. A 75-ml portion of ether was added to the mixture and the solution was washed twice with 35-ml portions of water. The ether layer was then dried and concentrated to obtain 1.49 g of crude **5b**. Crystallization from pentane afforded 848 mg (48%) of white crystals. An analytical sample was obtained by several crystallizations from pentane: mp 50.0–51.0°, infrared spectrum (CCl₄) 3050, 2950, 1585, 1190, 1100, 1072, 1018, and 923 cm⁻¹; nmr (CDCl₃) τ 2.27 (s), 4.11 (s), 5.99 (tr), 7.52 (s), 8.0–9.1 (mult).

Anal. Calcd for C₁₆H₁₉O₃SBr: C, 51.74; H, 5.16; S, 8.64. Found: C, 52.02; H, 5.12; S, 8.69.

2-(endo-Bicyclo[3.2.1]oct-6-en-3-yl)ethyl-1,1-d₂ p-Bromobenzenesulfonate (6b). To 0.428 g (0.0102 mol) of LiAlD₄ in 150 ml of ether at reflux was added dropwise 1.70 g (0.0102 mol) of **4** in 15 ml of ether. The normal base work-up afforded 1.52 g (97%) of crude dideuterio alcohol **6a**.

To a solution of 1.52 g (9.37 mmol) of **6a** in 13 ml of dry tetrahydrofuran was added 6.5 ml of a 15% *n*-butyllithium solution in hexane. After being stirred for 1 hr, 3.040 g (11.9 mmol) of *p*-bromobenzenesulfonyl chloride in 15 ml of dry tetrahydrofuran was added dropwise. The usual work-up gave 1.235 g (33.5%) of white crystalline **6b**. Repeated crystallization from pentane gave an analytical sample: mp 51.0–52.0°; infrared spectrum (CCl₄) 3050, 2930, 2250, 2160, 1530, 1375, 1188, 1097, 1070, and 1012 cm⁻¹; nmr (CDCl₃) τ 2.45 (s, 4 H), 4.26 (s, 2 H), 7.58 (br s, 2 H), 9.2–7.9 (mult). No α protons were detectable.

Anal. Calcd for C₁₆H₁₇D₂O₃SBr: C, 51.48; H, 5.12. Found: C, 51.40; H, 5.18.

3-exo-Bicyclo[3.2.1]octyl p-toluenesulfonate was prepared by a combination of the methods of Moore, Moser, and LaPrade⁶ and Hill and Jefford.⁹ The melting point (75–76°) and spectra were consistent with the literature.

3-endo-Bicyclo[3.2.1]octyl Acetic Acid. To 60 ml of *tert*-butyl alcohol, freshly distilled from sodium, was added 0.298 g (7.45 mg-atoms) of potassium metal. Upon complete solution of the potassium, 1.220 g (7.60 mmol) of freshly distilled diethylmalonate was added dropwise. The mixture was allowed to stir at reflux under nitrogen for another 0.5 hr and 1.738 g (6.21 mmol) of *p*-toluenesulfonate dissolved in 15 ml of hot *tert*-butyl alcohol was added in one portion. Most excess *tert*-butyl alcohol was removed by distillation leaving a thick slurry. After 17 hr at reflux, the slurry was cooled and poured into ice water. Isolation and subsequent hydrolysis of the diester were carried out as in the preparation of **3b** to give 1.168 g of crude diacid. Without further purification, the crude diacid was decarboxylated in 25 ml of pyridine at reflux for 2 hr. The usual work-up gave 0.522 g (49.3% overall) of white needles. Recrystallization from ether–pentane provided an analytical sample: mp 54–57°; infrared spectrum (CCl₄) 3300–2500, 1720, 1365, 1220, 1150, 955, 780, and 765 cm⁻¹.

Anal. Calcd for C₁₀H₁₆O₂: C, 71.39; H, 9.58. Found: C, 71.21; H, 9.28.

2-(endo-Bicyclo[3.2.1]octyl)ethanol. To 0.140 g (3.7 mmol) of LiAlH₄ stirred in 75 ml of ether was added dropwise a solution of 3.11 g (1.35 mmol) of acid in 10 ml of ether. The mixture was allowed to stir at room temperature for 14 hr and then the reaction was terminated with the normal base work-up. Evaporation of the solvent gave 0.134 g of crude alcohol: infrared spectrum (film) 3300, 2920, 1050, 1030, 1010, 930, 913, and 880 cm⁻¹.

2-(endo-Bicyclo[3.2.1]octyl)ethyl p-bromobenzenesulfonate (7) was prepared by the method described for preparation of the unsaturated sulfonate ester **5b**. The quantities used were 0.284 g (1.87 mmol) in 3 ml of tetrahydrofuran, 1.3 ml of 15% *n*-butyllithium in hexane, and 0.612 g (2.3 mmol) of *p*-bromobenzenesulfonyl chloride in 4 ml of tetrahydrofuran. Work-up gave 0.533 g (76%) of **7** as an uncrystallizable liquid: infrared spectrum

(film) 2920, 1580, 1367, 1195, 1100, 1073, 1015, broad band 950, and 825 cm⁻¹.

2-(endo-Bicyclo[3.2.1]oct-6-en-3-yl)ethyl Chloride (8). To 8.5 g (22.9 mmol) of **5b** in a 125-ml Pyrex tube were added 2.038 g (45.8 mmol) of lithium chloride and 100 ml of dry acetone. The tube was purged with nitrogen, sealed, and heated at 100° for 38 hr in an oil bath. The reaction mixture was poured into 300 ml of ice water and extracted with three 30-ml portions of pentane. The combined extracts were dried, concentrated, and distilled at 61–63° (6.7 mm) to obtain 3.49 g (89.5%) of **8**: infrared spectrum (film) 3050, 2930, 2860, 1302, 1283, and 740 cm⁻¹; nmr τ 4.20 (s, 2 H), 6.64 (tr, 2 H), 7.55 (br s, 2 H), 7.89–9.2 (mult).

2-(endo-Bicyclo[3.2.1]oct-6-ol-3-yl)ethyl Chloride (9). To 6.533 g (20.5 mmol) of mercuric acetate being stirred in 20.5 ml of water and 14.0 ml of tetrahydrofuran was added 3.490 g (20.5 mmol) of chloride **8** in 7 ml of tetrahydrofuran. The mixture was allowed to stir for 20 min. To the resulting solution was added 20.5 ml of 3 *N* sodium hydroxide followed by 29 ml of a 3 *N* solution of sodium hydroxide which was 0.05 *N* in sodium borohydride. The mixture was allowed to stir overnight and the liquid decanted from the mercury into 300 ml of ice water. Subsequent extraction of the mixture with three 70 ml portions of ether, washing with two 20-ml portions of water, and drying, gave, upon concentration and distillation of the residue at 100° (0.5 mm), 3.35 g (86.5%) of clear viscous product: infrared spectrum (film) 3350, 2920, 1060, 1012, 720, and 658 cm⁻¹; nmr τ 6.02 (d of d, 1 H), 6.12 (s, 1 H), 6.53 (tr, 2 H), 7.5–9.2 (mult).

2-(endo-Bicyclo[3.2.1]oct-6-on-3-yl)ethyl Chloride (10). To 3.53 g (17.8 mmol) of pure **9** dissolved in 25 ml of ether was added dropwise, 10 ml of a mixture prepared from 3.98 g of Na₂Cr₂O₇·2H₂O, 20 ml of water, and 2.98 ml of concentrated sulfuric acid. The reaction was then allowed to stir for 3 hr at room temperature. The mixture was poured into 200 ml of ice water and extracted with three 50 ml portions of ether. The combined extracts were washed with two 15 ml portions of saturated sodium bicarbonate solution followed by two 20-ml portions of water. The ether extracts were dried and concentrated giving 3.09 g (93.4%) of crude keto chloride **10**. No further purification was undertaken: infrared spectrum (film) 2930, 1748, 715, and 660 cm⁻¹; nmr τ 6.53 (tr, 2 H), 7.4–9.2 (mult).

2-Protoadamantanone (11). To 50 ml of dry *tert*-butyl alcohol (freshly distilled from sodium) was added 1.077 g (27.6 mg-atoms) of potassium metal. The mixture was heated at reflux under a nitrogen atmosphere; 0.5 hr after the solution of the potassium, 4.286 g (23.0 mmol) of keto chloride was added dropwise in 10 ml of *tert*-butyl alcohol. The reaction was allowed to stir at reflux for 14 hr and then cooled and poured into 300 ml of ice water. The aqueous solution was saturated with sodium chloride and extracted with three 50-ml portions of pentane. The combined extracts were washed three times with 20-ml portions of water, dried, and concentrated. Chromatography on alumina (Merck-acid washed in a 30 to 1 weight ratio) of the concentrate gave 2.83 g (82%) of white crystalline **11**: mp 245–246° (lit.²⁹ mp 241–243°); infrared spectrum (CCl₄) 2930, 1743, 1460, 1385, 1190, 1128, 1092, 1080, and 875 cm⁻¹. The nmr showed only the expected multiplet from τ 7.50 to 9.0.

Reductions of 2-Protoadamantanone (11). A. **Lithium Aluminum Hydride in Ether**. To 0.152 g (4 mmol) of lithium aluminum hydride in 50 ml of dry ether was added dropwise 0.300 g (2 mmol) of ketone **11** in 10 ml of ether. The mixture was stirred overnight and worked up with base to give 0.302 g (99.4%) of solid alcohol containing 100% *2-endo*-protoadamantanol (**12a**). Recrystallization gave 0.293 g (96.4%) of pure crystalline **12a**: mp (sealed tube) 282–283.5° (lit.²⁹ mp 288–289°); infrared spectrum (CCl₄) 3640, 3450, 2930, 2875, 1100, 1077, 1055, 1003, 970, 945, and 898 cm⁻¹; nmr τ 5.71 (dd, $J_{AX} = 9.1$ and $J_{BX} = 4.5$ cps), 7.5–8.8 (mult), 7.92 (s) (lit.²⁹ nmr τ 5.78 ($J_{AX} = 9.0$ and $J_{BX} = 4.5$ cps for an ABX pattern)).

B. **Sodium Borohydride in Methanol**. A solution of 0.228 g (1.5 mmol) of ketone **11** in 12.5 ml of methanol was stirred at room temperature while 0.054 g (1.7 mmol) of sodium borohydride in a mixture of 1 ml of water and 5 ml of methanol was added. The mixture was stirred for 4 hr. Hydrolysis was effected by the addition of water and 15% potassium hydroxide solution. The solution was diluted with 60 ml of water and extracted with three 15-ml portions of ether. The combined ether extracts were washed with water, dried, and concentrated to obtain 0.224 g (98%) of solid alcohol, which analyzed as 100% **12a**.

C. **Sodium Borohydride in Pyridine**. To a solution of 0.100 g (6.7 mmol) of ketone **11** in 10 ml of dry pyridine being stirred at

room temperature was added 0.075 g (22 mmol) of sodium borohydride in 7.5 ml of pyridine. After 22 hr the reaction was worked up in the usual manner to obtain 0.082 g (80%) of 100% **12a** on analysis.

D. Sodium in Ethanol. To 0.100 g (6.7 mmol) of ketone **11** in 30 ml of ethanol at room temperature was added 4.60 g (0.2 g-atom) of sodium in small pieces over a period of 3 hr. The mixture was allowed to reflux on addition of the sodium. After 14 hr, the remaining sodium was destroyed by the addition of more ethanol and the solution was heated at reflux for 45 min. The cooled solution was heated at reflux for 45 min. The cooled solution was poured into 400 ml of water and continuously extracted with pentane for 16 hr, to afford 0.085 g (83%) of an alcohol mixture, consisting of 83% **12a** and 17% **13a**.

E. Sodium in Methanol. The previously described procedure for sodium in ethanol reduction was repeated substituting methanol for ethanol. Work-up as before gave 0.079 (77%) of an alcohol mixture which analyzed as 79% **12a** and 21% **13a**.

Equilibration of 2-endo-Protoadamantanol (12a). A. A mixture of 0.300 g (2.0 mmol) of endo alcohol **12a**, 0.492 g (2.0 mmol) of aluminum *tert*-butoxide, and 0.004 g (0.02 mmol) of fluorenone in 10 ml of benzene was sealed in a tube and heated at 150° for 252 hr. After cooling, the contents of the tube was diluted with 40 ml of ether washed with 10% hydrochloric acid until neutral, and then with saturated aqueous sodium bicarbonate solution. The ether solution was dried and concentrated to give 0.298 g (99%) of alcohol shown by infrared to be contaminated with fluorenone. Gas chromatographic analysis of the crude alcohol mixture indicated it to be 76% **12a** and 24% **13a**.

B. To a solution of 0.600 g (4.0 mmol) of endo alcohol **12a** in 50 ml of methanol was added 0.920 g (40.0 mg-atoms) of sodium in small pieces. A small amount of 2-protoadamantanone (0.015 g) was added and the mixture was heated at reflux for 325 hr under an argon atmosphere. Work-up as in the previous sodium in methanol reduction afforded 0.547 g (91.2%) of solid alcohol mixture which analyzed as 31% **12a** and 69% **13a**.

Trimethylsilylation of Alcohol Mixtures. To 10 mg of the alcohol mixture in a 1-dram vial fitted with a micro magnetic stirring bar was added 1 ml of silylating mixture (ten parts pyridine, two parts hexamethyldisilazane, and one part trimethylsilyl chloride). The mixture was capped and stirred for 12 hr, poured into 20 ml of ice water, and extracted with three 15-ml portions of pentane. The combined pentane extracts were washed with three 10-ml portions of cold 6 *N* hydrochloric acid, two 5-ml portions of saturated aqueous sodium bicarbonate solution, and two 10-ml portions of water. Drying and concentration afforded samples used for gas chromatographic analyses.

2-exo-Protoadamantanol (13a). The sodium in methanol equilibrium mixture of alcohols (0.520 g) described above was chromatographed on 50 g of neutral alumina (Merck, pH 7.2) using pentane and varying amounts of ether as eluents. The ketone **11** began to elute after eighteen 25-ml fractions of 100% pentane and continued over the next three fractions. The eluent was then changed to 1% ether-pentane and the endo alcohol began to elute on the twenty-fifth fraction, and continued through the thirty-first fraction giving 0.156 g of pure alcohol **12a**. The exo alcohol began eluting on the thirty-third fraction and 5% ether-pentane was used to elute the remainder of this alcohol. The separation afforded 0.343 g (66%) of pure exo alcohol **13a**: mp 215–217°; infrared spectrum (CCl₄) 3640, 3350, 2930, 2875, 1157, 1106, 1045, 1029, 1012, 935, 892, and 880 cm⁻¹; nmr τ 6.01 (d, 1 H, $J = 1$ cps), 7.7–8.9 (mult).

2-endo-Protoadamantyl *p*-Bromobenzenesulfonate (12b). To a solution of 0.764 g (4.7 mmol) of **12a** in 7 ml of tetrahydrofuran was added 3.3 ml of a 15% *n*-butyllithium solution in hexane. After being stirred for 1 hr, 1.329 g (5.2 mmol) of *p*-bromobenzenesulfonyl chloride in 10 ml of tetrahydrofuran was added. Work-up in the usual fashion and recrystallization from ether-pentane afforded 1.410 g (81%) of the pure crystalline ester **12b**, mp 92.5–93.5°. An analytical sample obtained by repeated recrystallizations gave infrared spectrum (CCl₄) 2930, 2875, 1580, 1395, 1375, 1195, 1100, 1070, 1012, 960, 920, and 870 cm⁻¹; nmr τ 2.27 (d, 4 H), 5.08 (dd, 2 H, ABX pattern where $J_{AX} = 9.3$ and $J_{BX} = 5.0$ cps), 7.4–8.9 (mult).

Anal. Calcd for C₁₆H₁₅O₃SBr: C, 51.74; H, 5.16; S, 8.64. Found: C, 52.32; H, 5.12; S, 8.44.

2-exo-Protoadamantyl *p*-Bromobenzenesulfonate (13b). The procedure used was identical with that employed for the endo isomer. Quantities used were 0.320 g (2.1 mmol) of exo alcohol **13a** in 3 ml of tetrahydrofuran, 1.4 ml of a 15% *n*-butyllithium solution in hexane, and 0.587 g (2.3 mmol) of *p*-bromobenzenesulfonyl chloride

in 5 ml of tetrahydrofuran. The usual work-up gave 0.677 g (87%) of pure ester **13b** as white plates after crystallization from ether-pentane. An analytical sample was prepared by several recrystallizations from ether-pentane: mp 118.5–119.5°; infrared spectrum (CCl₄) 2930, 2875, 1580, 1395, 1372, 1272, 1195, 1180, 1100, 1072, 1015, 960, 935, 915, and 900 cm⁻¹; nmr τ 2.27 (d, 4 H), 5.29 (d, 1 H, $J = 1.7$ cps), 7.6–9.0 (mult).

Anal. Calcd for C₁₆H₁₅O₃SBr: C, 51.74; H, 5.16; S, 8.64. Found: C, 51.98; H, 4.96; S, 8.88.

Acetolysis Product Studies. To 0.020 g (5.39 × 10⁻⁶ mol) of ester in a glass tube was added 10 ml of 0.00987 *M* sodium acetate in acetic acid containing 1% acetic anhydride. The tube was flushed with nitrogen, sealed, and heated at constant temperature for approximately eight half-lives. Duplicate samples were utilized for each temperature and ester. For *p*-bromobenzenesulfonate **5b**, samples were run at 60, 80, and 100°. Studies were conducted with no buffer and with sodium acetate or urea as a buffer. The acetolyses of 2-*exo*- and 2-*endo*-protoadamantyl *p*-bromobenzenesulfonate esters (**13b** and **12b**) were conducted at 60 and 80°, and at 100 and 130°, respectively. The solutions were buffered with sodium acetate. After cooling, the contents of the tubes were poured into 20 ml of water and extracted with three 15-ml portions of pentane. The combined extracts were washed with saturated sodium bicarbonate solution until the washings were basic. After drying and concentration, several methods of analysis were employed. Since the acetates could not be efficiently separated on any available gas chromatography column, they were reduced with lithium aluminum hydride (0.030 g, 0.8 mmol) in ether (15 ml) to obtain the corresponding alcohols in quantitative yield. Trimethylsilylation of approximately 2 mg of the alcohol mixture afforded derivatives which allowed effective gas chromatographic analysis of the mixture. The remaining alcohol mixture was oxidized to the corresponding ketones by one of two methods both giving the same product ratios.

Method A.¹⁰ To a solution of approximately 0.008 g of the alcohol mixture in 5 ml of ether was added a large excess (3 ml) of a chromic acid oxidizing mixture (2.5 g of Na₂Cr₂O₇ · 2H₂O and 1.9 ml of 96% sulfuric acid diluted to 12.5 ml with water). After being stirred for 0.5 hr, the reaction was worked up in the usual manner to obtain a quantitative yield of the ketones.

Method B.³¹ To a solution of 2 g of Cr₂O₃ · 2Py in 10 ml of dry methylene chloride was added approximately 0.008 g of the solvolysis derived alcohol mixture in 2 ml of methylene chloride. After the precipitate disappeared (~20 min), the reaction was worked up in the usual way to obtain a good yield of the corresponding ketones. The trimethylsilyl ethers and ketones were analyzed by gas chromatography.

Formolysis Product Studies. Formic acid (Analab Inc., North Haven, Conn.; 97–100%) was fractionally distilled through a 40-cm fractionating column. A middle cut was used distilling at 101°. A 0.01 *M* sodium formate buffered solution was prepared by the solution of 0.265 g of anhydrous sodium carbonate in 500 ml of the freshly distilled formic acid. The sample tubes were prepared in a manner identical with the described acetolysis procedure. The formolyses of the *p*-bromobenzenesulfonates **5b** and **13b** were effected at 80° for approximately eight half-lives, while **12b** was solvolyzed at 100°. Duplicate runs were carried out for each compound. Work-up and analysis of the product mixtures were carried out as in acetolysis. (Note: the tubes were opened by breaking in a metal bomb since they showed a tendency to explode on opening.)

Trifluoroacetolysis Product Studies. A 0.01 *M* solution of sodium trifluoroacetate in trifluoroacetic acid was prepared from 0.68 g of sodium trifluoroacetate and 500 ml of freshly distilled (bp 72.5°) trifluoroacetic acid containing 1% of trifluoroacetic anhydride. Samples were prepared as before and heated at 80 and 100°, for the exo and endo isomers, respectively. The products were analyzed by gas chromatography.

Separation of Solvolysis Derived Ketones. All acetolysis kinetic samples for the *endo*- and *exo*-*p*-bromobenzenesulfonates **12b** and **13b** were combined and the acetates isolated. After reduction of these esters, 10 mg of the solid alcohol mixture was converted to the trimethylsilyl ethers in order to confirm that the product ratio was similar to those of the product studies. The remaining alcohol mixture (0.24 g) was oxidized to ketones by method B and chromatographed on 20 g of neutral alumina.

To obtain samples of **19**, **20**, and **22**, a trifluoroacetolysis was carried out at 80° for 2 hr with 0.400 g of 2-*exo*-protoadamantyl *p*-

(31) J. C. Collins, W. W. Fess, and F. J. Frank, *Tetrahedron Lett.*, 3363 (1968).

bromobenzenesulfonate **13b**. A 0.01 *M* sodium trifluoroacetate-trifluoroacetic acid solution containing 1% trifluoroacetic anhydride was employed. After work-up and reduction of the product esters, the alcohol mixture (0.147 g, 92%) was converted to the ketones as before. The ketones (0.100 g) were chromatographed on neutral alumina to give partial separations of the eight isomers present.

Isomers **17**, **19**, and **20**, which could not be obtained pure from column chromatography, were separated by preparative gas chromatography.

Structure Identification Procedures. A. Conversion of Solvolysis Products to Hydrocarbons. The procedure of Whitlock and Siefken²⁹ was used to convert the solvolysis derived ketones to hydrocarbons. To a solution of 40 mg (0.27 mmol) of trifluoroacetolysis derived ketone mixture in 4 ml of triethylene glycol was added 0.25 ml (5 mmol) of hydrazine hydrate and 4 drops of acetic acid. After the subsequent base treatment, the reaction was worked up and the residue examined by gas chromatography. Of the eight trifluoroacetolysis ketones, it was determined that three possessed the protoadamantane carbon skeleton.

B. Isotopic Labeling of Solvolysis Derived Ketones. A gas chromatography column was prepared for deuteration of the active α positions of carbonyl compounds. This column was capable of exchange of deuterium in excess of 85% of theoretical exchange on one pass through the column. Samples were collected in cooled capillary tubes and analyzed by mass spectrometry. Spectra of each ketone were taken before and after deuteration. The ketones which exchanged two deuterium atoms and lost a ketene (or dideuterio-ketene) fragment were **17**, **18**, and **21**.

C. Structure Proofs of Solvolysis Derived Ketones. 2-Protoadamantanone (**11**) was identified from its infrared spectrum and retention time which were identical with those of an authentic sample previously prepared.

4-Twistanone (17). Due to an inability to easily obtain an authentic sample of this material, the following information was utilized in deduction of structure. Ketone **17** exhibited an infrared carbonyl absorption at 1720 cm^{-1} (lit.¹⁶ 1718 cm^{-1}). Exchange experiments indicated that two deuterium atoms were incorporated per molecule of ketone. Reduction with lithium aluminum hydride and trimethylsilylation of the resultant alcohol gave a single trimethylsilyl ether, which possessed identical gas chromatography retention time to the trimethylsilyl ether of the solvolysis derived alcohol.

2-Adamantanone (15) was identified by comparison of its infrared spectrum and gas chromatography retention time with that of a commercially obtained sample.

2-Isotwistanone (18). The previously described column chromatography of the acetolysis derived ketones gave a homogeneous crystalline sample (mp 113–114°) of the major component: infrared spectrum (CCl_4) 2945, 2875, 1740, 1458, 1412, 1292, 1182, 1145, 1135, 1022, 950, and 942 cm^{-1} . The mass spectrum showed by a large peak at *m/e* 108 a strong tendency for loss of a ketene (or dideuterio-ketene) fragment and deuterium exchange (M^+ , *m/e* 152).

An nmr spectrum of the alcohol mixture from the reduction of the solvolysis acetates revealed an ABX pattern for the CHOH proton centered at τ 6.00 where $J_{AX} = 6.0$ and $J_{BX} = 2.5$ cps.

Reduction of the ketone with lithium aluminum hydride in ether gave only one alcohol whose trimethylsilyl ether derivative differed from the solvolysis derived trimethylsilyl ether by 1.3 min.

9-Protoadamantanone (19). The ketone was obtained from two isomeric trifluoroacetolysis products. Its infrared absorption maxima at 1740 and 1748 cm^{-1} were consistent for a strained five-membered ring ketone. No deuterium was incorporated on passage through the deutering column. The mass spectrum showed no mass peak at *m/e* 108. Wolff-Kishner reduction gave protoadamantanone.

7-Protoadamantanone (20). The infrared maximum for the carbonyl stretching frequency occurred at 1736 cm^{-1} . The mass spectrum of the ketone collected from the deutering gas chromatography column showed a parent ion *m/e* 150 (no deuterium incorporation) and no peak at *m/e* 108 corresponding to loss of a ketene fragment. Conversion to the hydrocarbon gave protoadamantanone.

2-Isoprotoadamantanone (21). The infrared maxima corresponding to carbonyl stretching frequencies occurred at 1736 and 1740 cm^{-1} . The ketone was observed to exchange deuterium. The mass spectrum of the deuterated ketone gave prominent ion peaks at *m/e* 152 (parent), 108 ($\text{P} - \text{C}_2\text{H}_5\text{O}$), and 79 (base peak). Reduction with lithium aluminum hydride and trimethylsilylation gave two trimethylsilyl ethers in a ratio of approximately 1 to 10. The larger peak was identical in retention time (22.8 min) with the solvolysis derived trimethylsilyl ether.

Kinetic Studies. J. T. Baker Co. reagent grade analyzed glacial acetic acid, containing 1% by weight of added acetic anhydride, was used for the acetolysis runs, and in the preparation of the standard solution. Standard perchloric acid (0.0120 *N*) in glacial acetic acid was prepared and standardized against potassium acid phthalate. A 0.00987 *N* sodium acetate solution in glacial acetic acid was prepared and standardized against standard perchloric acid in glacial acetic acid.

The indicator used was a 0.2% solution of Crystal Violet in glacial acetic acid. Three drops were used in each sample. The end point for all titrations was taken as the point at which no violet color could be detected.

The constant temperature bath, a Neslab TEX9-H, was filled with Dow-Corning 200 silicon oil. Temperatures were determined with National Bureau of Standards calibrated thermometers.

All acetolysis kinetics were run following the same general procedure. In the sodium acetate buffered runs, the *p*-bromobenzenesulfonate was weighed into a 50-ml volumetric flask and was diluted to volume with standard sodium acetate in glacial acetic acid. Aliquots (5 ml) of this solution were sealed in Pyrex 864 tubes and submerged in the constant temperature bath. At appropriate time intervals, tubes were withdrawn and rapidly cooled in ice-water, and the contents were titrated with standard perchloric acid. In the unbuffered runs, a 3-ml aliquot of standard sodium acetate solution in glacial acetic acid was added before titration. A 5-ml microburet which could be read to 0.01 ml was used in all titrations.

Infinity titers were taken at approximately eight half-lives. Due to relatively slow rates of solvolysis, zero time was taken as the time the tubes were immersed in the bath. The first-order rate constants were determined by a computer (IBM 360) fitted least squares plot of $\ln[\text{ROBS}]$ vs. time.

Acknowledgment. We are grateful to the National Institutes of Health for generous support of this work (Grant No. AI 09670-01).